

FONTANA NAPOLI COMMERCIAL HANDS FREE AUTOMATIC SENSOR COMMERCIAL LIQUID SOAP DISPENSE SPECS

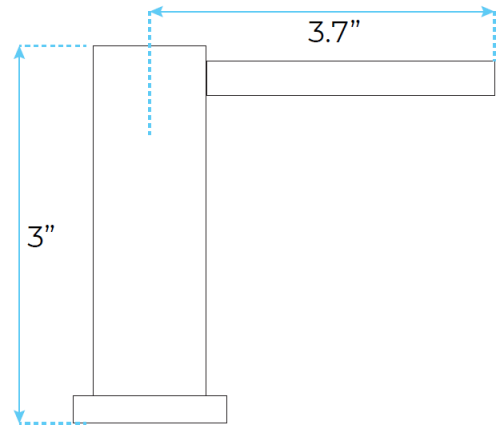

SPECS:

- Product Type: Commercial
- Main Construction Material: Brass
- Mount Type: Deck
- Handle Type: Infra-Red
- Power Rating: 3 Amp Fuse, AC: 230V
DC: 1.5V
- Batteries Required: 4 AA Batteries (not supplied)
- Number of Tap Holes: 1
- Valve/Cartridge Type: Solenoid Valve
- Plumbing System Requirements:
Suitable for all plumbing systems
- Sensing Range: 0 - 8cm
- Activation Time: 0.5 - 1 secs
- Viscosity of Liquid Soap: 100-3500cp (mpA .s)
- Isolation Included: No

